

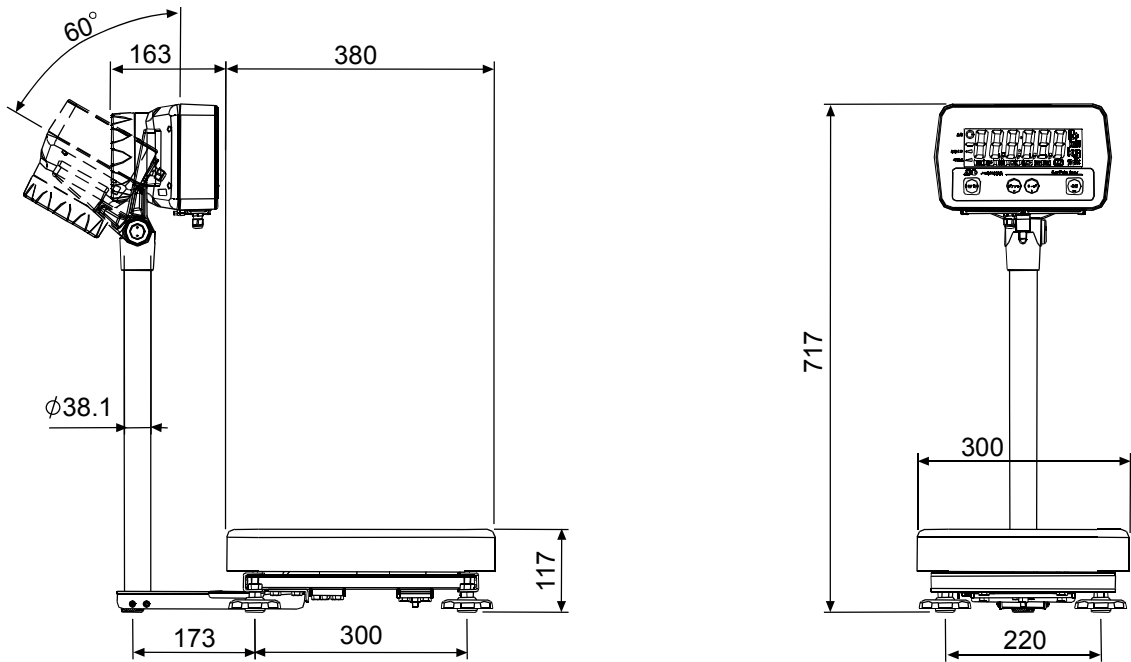

12.2. 外形寸法

●SC-30KAM-K / SC-60KAM-K / SC-150KAM-K



●SC-60KAL-K / SC-150KAL-K

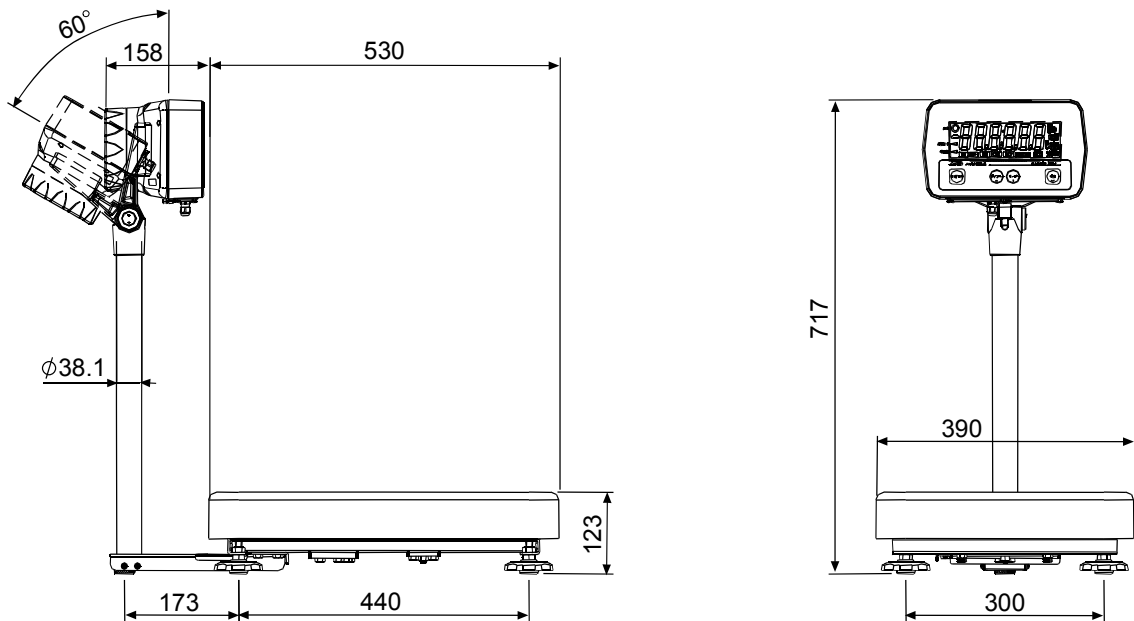

単位 : mm

●SC-30KBM-K / SC-60KBM-K / SC-150KBM-K

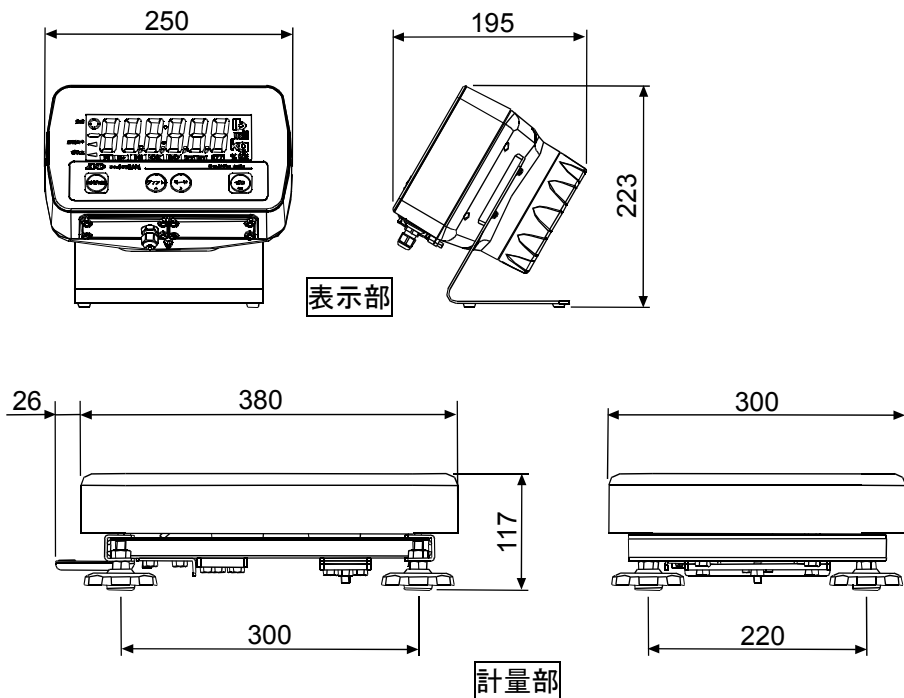

●SC-60KBL-K / SC-150KBL-K

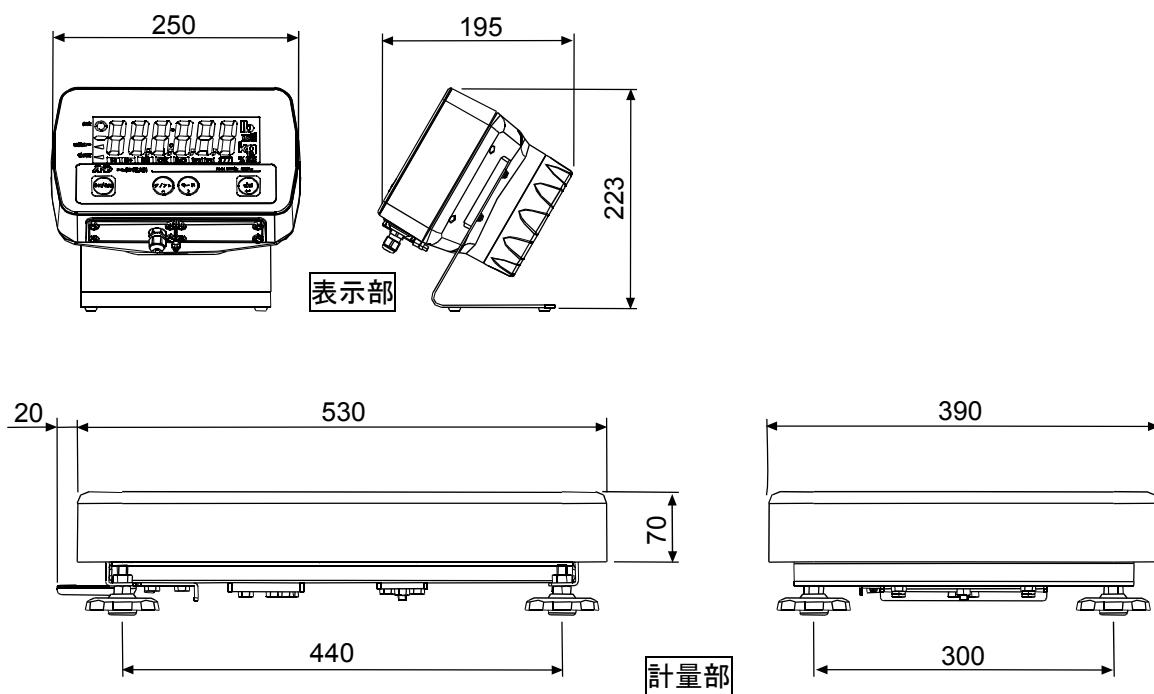

単位 : mm